

11799 Beechnut

Houston, Texas

Pre-Leasing Now

- ◆ Availability: Spring 2006
- ◆ Total Size: 7,000 SF Retail
- ◆ Next to Wal-Mart Grocery

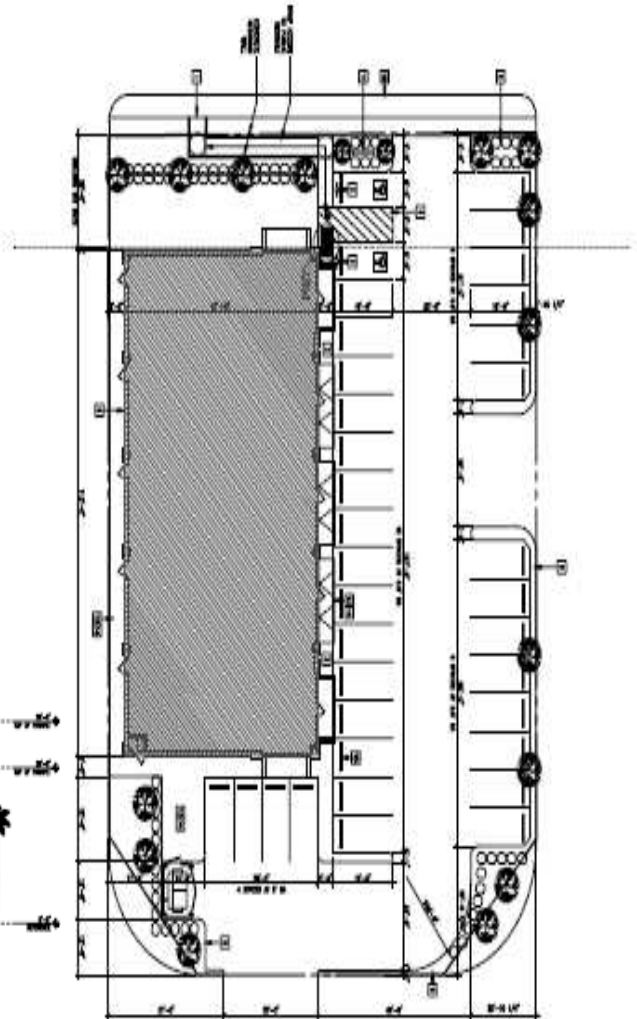
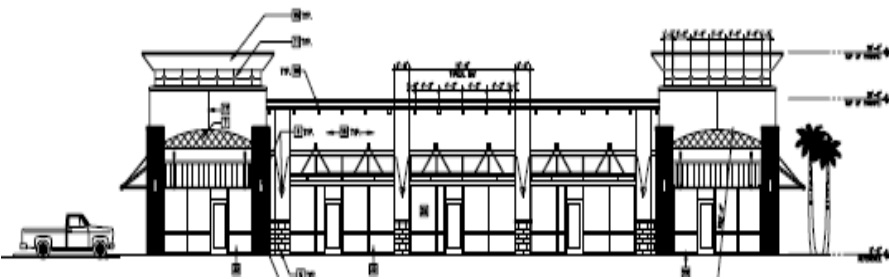

FOR LEASING INFORMATION CALL:

VINCENT WORLEY

P: 713-827-1800

F: 832-379-1800

vincent@worleycommercial.net

Andrew Tran

P: 832-868-4848

F: 832-379-1800

andrew@worleycommercial.net

WORLEY COMMERCIAL BROKERAGE SERVICES, INC.

www.worleycommercial.net

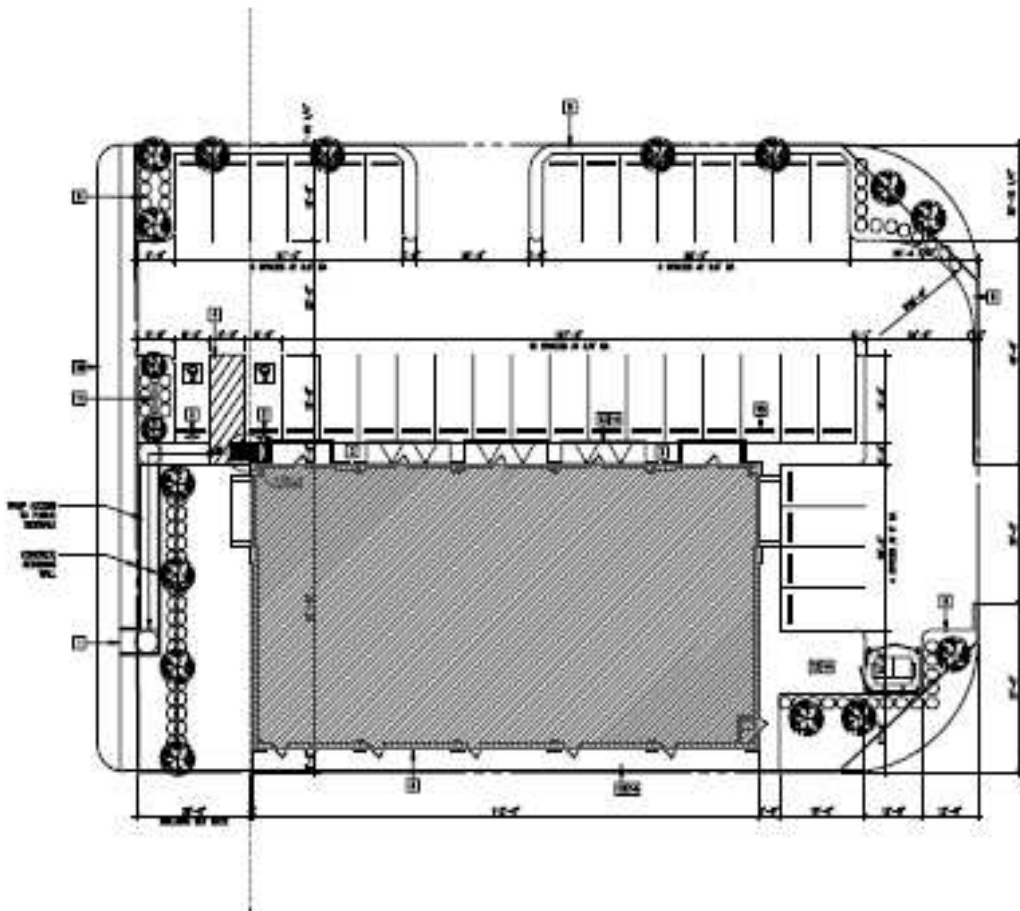

Approved by the Texas Real Estate Commission for Voluntary Use

Texas law requires all real estate licensees to give the following information about brokerage services to prospective buyers, tenants, sellers and landlords.

Information About Brokerage Services

Before working with a real estate broker, you should know that the duties of a broker depend on whom the broker represents. If you are a prospective seller or landlord (owner) or a prospective buyer or tenant (buyer), you should know that the broker who lists the property for sale or lease is the owner's agent. A broker who acts as a subagent represents the owner in cooperation with the listing broker. A broker who acts as a buyer's agent represents the buyer. A broker may act as an intermediary between the parties if the parties consent in writing. A broker can assist you in locating a property, preparing a contract or lease, or obtaining financing without representing you. A broker is obligated by law to treat you honestly.

IF THE BROKER REPRESENTS THE OWNER:

The broker becomes the owner's agent by entering into an agreement with the owner, usually through a written listing agreement, or by agreeing to act as a subagent by accepting an offer of subagency from the listing broker. A subagent may work in a different real estate office. A listing broker or subagent can assist the buyer but does not represent the buyer and must place the interests of the owner first. The buyer should not tell the owner's agent anything the buyer would not want the owner to know because an owner's agent must disclose to the owner any material information known to the agent.

IF THE BROKER REPRESENTS THE BUYER:

The broker becomes the buyer's agent by entering into an agreement to represent the buyer, usually through a written buyer representation agreement. A buyer's agent can assist the owner but does not represent the owner and must place the interests of the buyer first. The owner should not tell a buyer's agent anything the owner would not want the buyer to know because a buyer's agent must disclose to the buyer any material information known to the agent.

IF THE BROKER ACTS AS AN INTERMEDIARY:

A broker may act as an intermediary between the parties if the broker complies with The Texas Real Estate License

Act. The broker must obtain the written consent of each party to the transaction to act as an intermediary. The written consent must state who will pay the broker and, in conspicuous bold or underlined print, set forth the broker's obligations as an intermediary. The broker is required to treat each party honestly and fairly and to comply with The Texas Real Estate License Act. A broker who acts as an intermediary in a transaction:

- (1) shall treat all parties honestly;
- (2) may not disclose that the owner will accept a price less than the asking price unless authorized in writing to do so by the owner;
- (3) may not disclose that the buyer will pay a price greater than the price submitted in a written offer unless authorized in writing to do so by the buyer; and
- (4) may not disclose any confidential information or any information that a party specifically instructs the broker in writing not to disclose unless authorized in writing to disclose the information or required to do so by The Texas Real Estate License Act or a court order or if the information materially relates to the condition of the property.

With the parties' consent, a broker acting as an intermediary between the parties may appoint a person who is licensed under The Texas Real Estate License Act and associated with the broker to communicate with and carry out instructions of one party and another person who is licensed under that Act and associated with the broker to communicate with and carry out instructions of the other party.

If you choose to have a broker represent you, you should enter into a written agreement with the broker that clearly establishes the broker's obligations and your obligations. The agreement should state how and by whom the broker will be paid. You have the right to choose the type of representation, if any, you wish to receive. Your payment of a fee to a broker does not necessarily establish that the broker represents you. If you have any questions regarding the duties and responsibilities of the broker, you should resolve those questions before proceeding.

Real estate licensee asks that you acknowledge receipt of this information about brokerage services for the licensee's records.

Buyer, Seller, Landlord or Tenant

Date

Texas Real Estate Brokers and Salespersons are licensed and regulated by the Texas Real Estate Commission (TREC). If you have a question or complaint regarding a real estate licensee, you should contact TREC at P.O. Box 12188, Austin, Texas 78711-2188 or 512-465-3960.



01A TREC No. OP-K